



HIKVISION Anti-IR Reflection Dome Camera

Provides clear image
in all environment

Table of Content

1. Background	3
2. Key Technologies	3
2.1. Patented Bubble	4
2.2. New 3-Axis Adjustment	6
3. Test Result	7
4. Summary	9

1. BACKGROUND

The IR dome camera is able to provide clear video at night. The most of the dome cameras are composed by the camera module and the bubble. The bubble can protect the camera module from dust and water, and extend the lifespan of the camera.

At night, the camera emits IR light to all directions to capture clear images. For the ordinary dome camera, there is a lightproof ring placed inside the dome cover, which can prevent a part of the IR light directly entering the lens. Even so, some of the IR light still enters the lens after reflecting for many times in the bubble wall. As a result, those lights enter the sensor and make the image dimness. Especially, if there's dust or water on the bubble, the IR reflection influence gets more serious. Obvious white spots appear on the image, which will badly reduce the image quality.



Figure 1 Image Dimness Caused by IR Reflection

Therefore, how to solve the image quality blemish caused by the IR reflection is the most concerned problem for the IR dome camera development. Hikvision comes up with an anti-IR reflection solution that can avoid the IR light reflecting to the lens and effectively improve the image quality at night.

2. KEY TECHNOLOGIES

The Hikvision anti-IR reflection dome camera adopts the EXIR lamps, a bubble that composed by separated IR passing zone and imaging zone, and the new-type 3-axis adjustment. With the several new technologies, the IR reflection problem is solved.

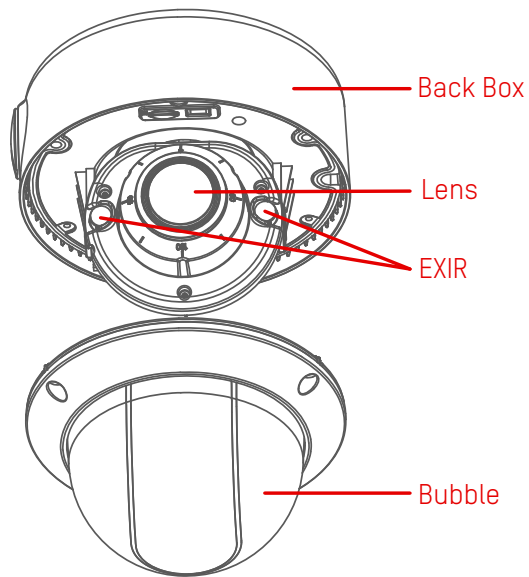

Figure 2 Hikvision Anti-IR Reflection Dome Camera

2.1. PATENTED BUBBLE

Hikvision anti-IR reflection camera adds a black U-shape lightproof loop on the bubble, which can effectively absorb the reflected IR light.

The anti-IR reflection bubble is divided into two parts: the imaging zone and the IR passing zone. The two zones are separated by the lightproof loop. Without the IR reflection problem, the camera is able to provide a better image when the IR light is on.

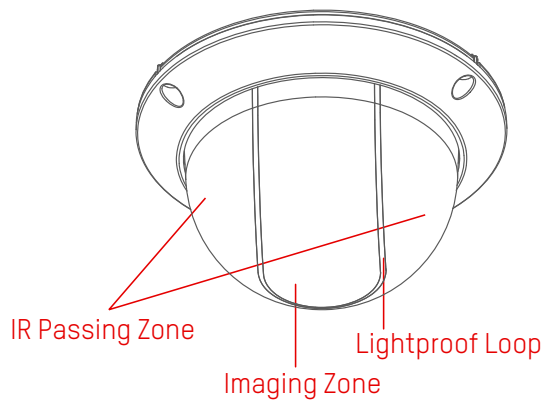

Figure 3 Hikvision Anti-IR Reflection Bubble

See the picture below for the cross-section diagram of ordinary camera (left) and Hikvision anti-IR reflection dome camera (right).

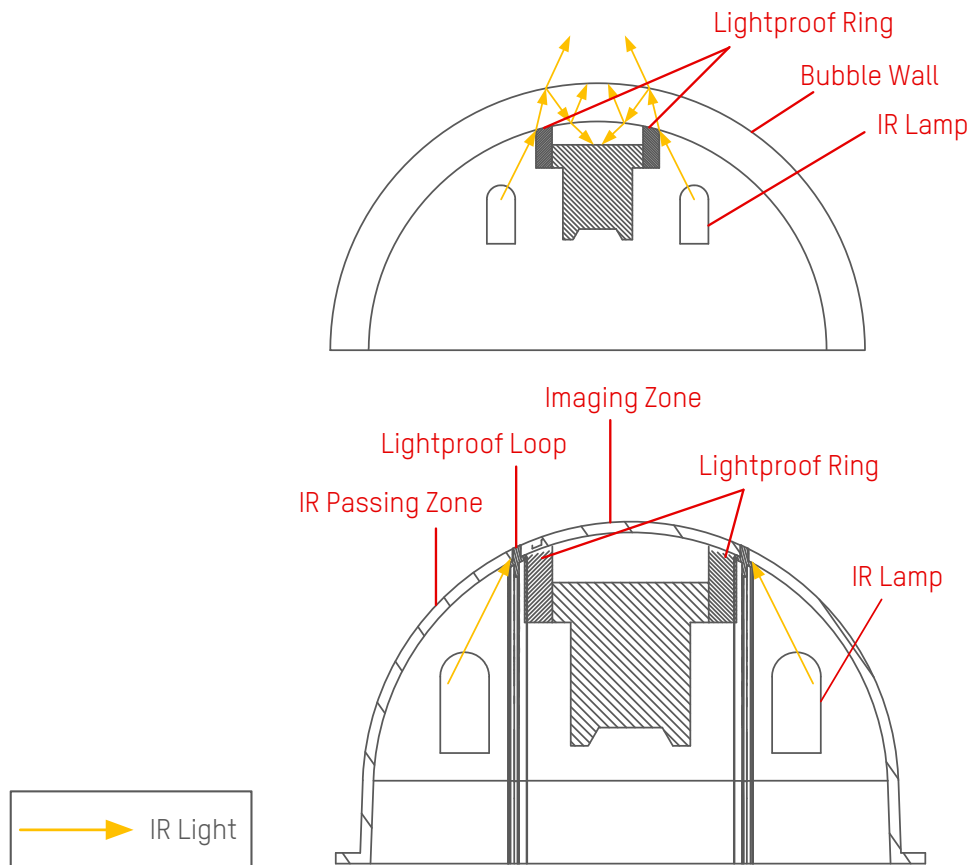

Figure 4 Ordinary IR Dome Camera (Up) and Hikvision Anti-IR Reflection Dome Camera (Down)

- Ordinary Camera: There's no shield between the lens and the sensor. The IR light will be reflected by the inner wall of the bubble, and then enter the lens and the sensor, which will influence the image quality.
- Hikvision Anti-IR Reflection Dome Camera: The bubble is composed by the imaging zone, the IR passing zone, and the lightproof loop. The lightproof loop separates the imaging zone and IR passing zone and can block the IR light out of the imaging zone, so as to protect the image from the IR light reflection influence.

At night, most of the IR light passes the IR passing zone, while there is still a part of IR light radiates to the lens, and the lightproof ring can block only a few of it. Since the lightproof loop is placed between the IR passing zone and the imaging zone, it can absorb the reflected IR light, therefore reduces the IR light that enters the lens and improve the image quality at night.

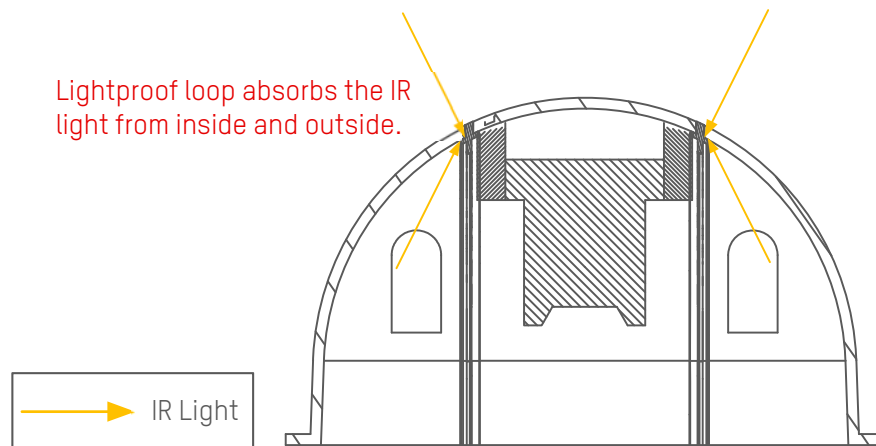

Figure 5 Lightproof Loop Absorbs the IR Light

In addition, the bubble is a one-time molded assembly that is hermetic, simple-constructed, stable and reliable. It makes the dome camera more reliable and covert.

2.2. NEW 3-AXIS ADJUSTMENT

Since the lightproof loop on the bubble is the key to prevent the IR light reflection to the lens, the position of the lens, the IR lamps and the lightproof loop is important. The IR lamps should be kept in the IR passing zone and the lens should always face the imaging zone.

Hikvision anti-IR reflection dome camera has integrated the camera module, IR lamps and the back box. The camera module is hinge jointed with the back box, and the IR lamps are fixed on two sides of the camera module. The camera module and the IR lamps are adjusted together, therefore the IR supplement direction is always same as the lens direction.

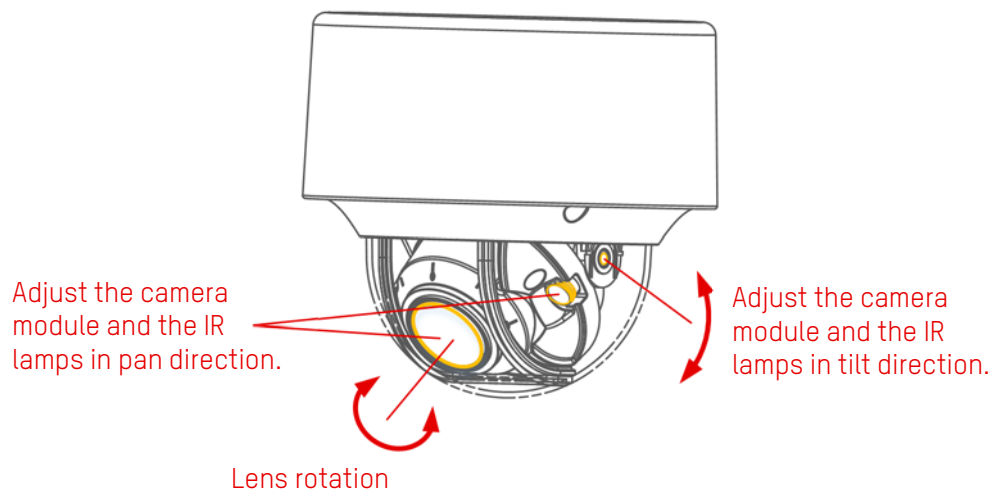

Figure 6 3-Axis Adjustment

The dome camera has unique fixing holes for the bubble, which synchronizes with the camera module all the time. In this way, the camera module synchronizes with the imaging

zone and the IR lamps synchronize with the IR passing zone.

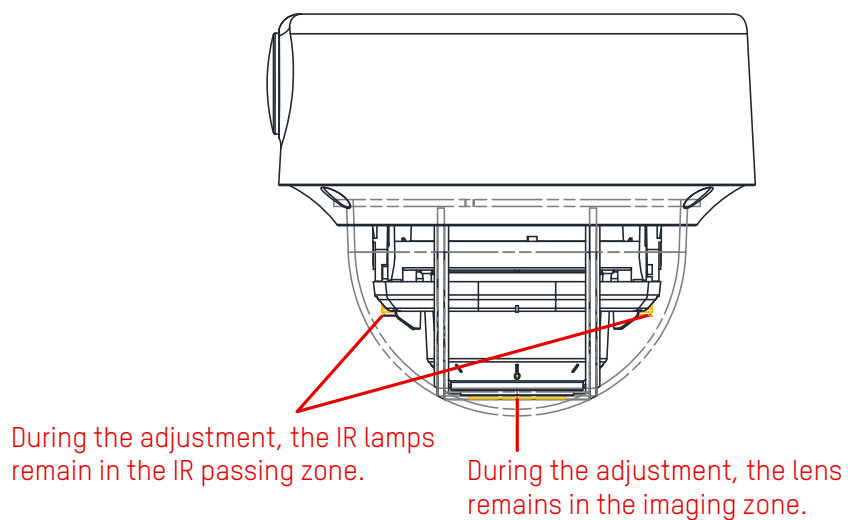

Figure 7 The Position of the Anti-IR Reflection Bubble and the Lens

3. TEST RESULT

See the following pictures for the test result when the ordinary IR dome camera (left) and Hikvision anti-IR reflection dome camera (right) in the same environment.

Test 1: Smear the same amount of dust on the surface of the bubble and compare the image.



Figure 8 Dusty Environment Test

Result: The image of the ordinary dome camera turns gray and dimness (left), while the image of Hikvision anti-IR reflection dome camera is still clear (right).

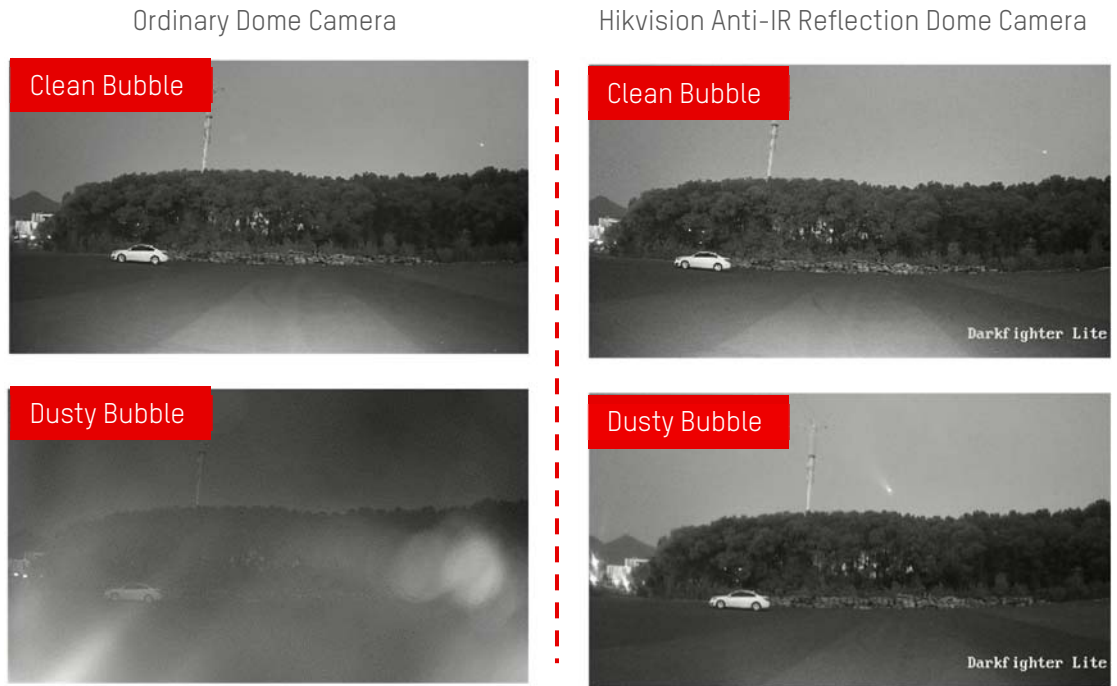

Figure 9 Test Result

Test 2: Spray the same amount of water on the surface of the bubble and compare the image.



Figure 10 Rainy Environment Test

Result: The image of the ordinary dome camera turns gray and dimness (left), while the image of Hikvision anti-IR reflection dome camera is still clear (right).

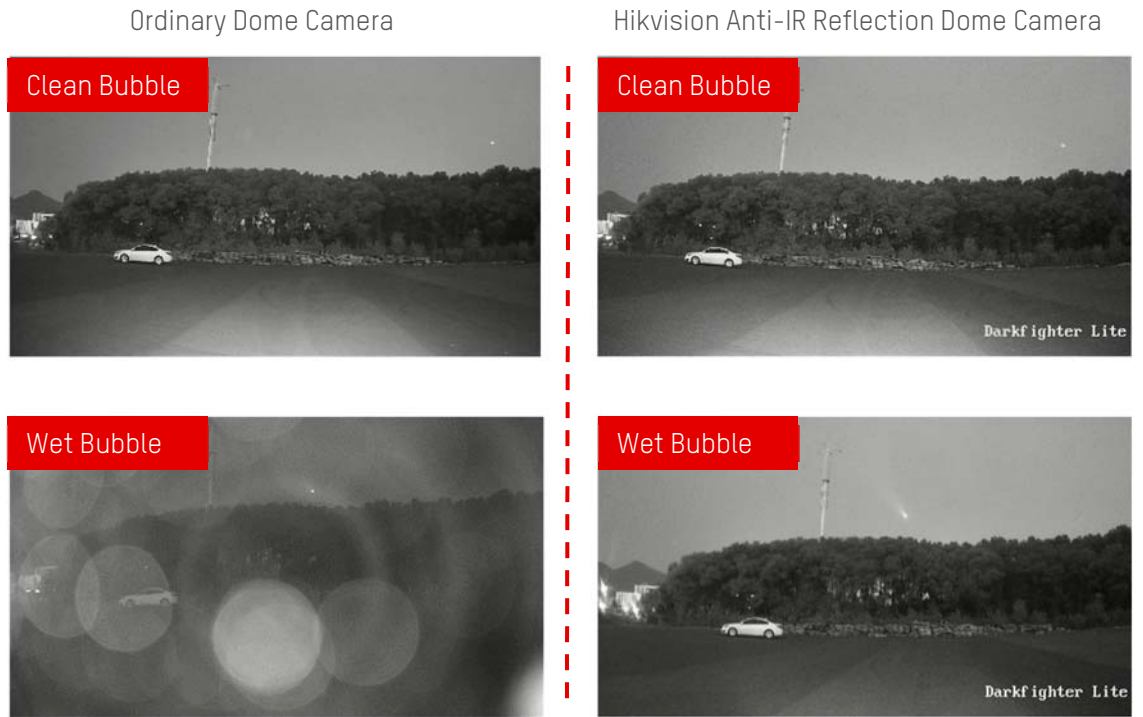

Figure 11 Test Result

4. SUMMARY

Hikvision anti-IR reflection solution has effectively solved the image dimness caused by the IR reflection and ensures the image clear at night, which can be applied on all kinds of IR dome camera. The anti-IR reflection dome cameras can be widely used at indoor and outdoor environment, especially the dusty and rainy outdoor environment.

HIKVISION

Hikvision HQ
No. 555 Qianmo Road
310052 Hangzhou
China
T +86 571 88075998
overseasbusiness@hikvision.com